

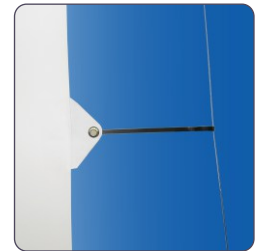

# Maxxscreen 20 TabTension



robust case



TabTension system

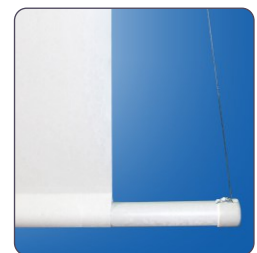

slat bar retracts into the case

## Highlights

- Large venue electric screen for trade shows, conference halls, theaters and cinemas
- Up to size of 600 cm width and 400 cm height
- The screen surface is given a high-quality coating after the welding, whereby the horizontal seams are not longer visible
- Perfectly flat viewing area with the use of lateral tensioning system
- High-quality, stable square 20x20 cm steel housing 1 mm steel sheet, white colour RAL9010
- Ceiling installation as standard
- Maintenance - free robust motor incl. thermo protection against overheating
- Easy and safe handling due to an electrical drive, rotary switch included
- Automatic electrical end switch at the top and bottom

## Optional

- Customized sizes, special colour of casing, different types of screens surfaces on request
- RF remote control
- Installation frame for integration into suspended ceilings
- Mounts for wall mounting

## Screen surface

- PVC based material with special coating
- Type D - matt white, Gain 1,0 / 1,4 / 1,6, back side white.
- Type S - highly reflective, Gain 1,8
- Type 3D - aluminium silver coating for passive 3D technologies using polarized light, Gain 1,7 / 2,0 / 2,2 / 2,4
- Type R - Rear projection
- Neve - front and rear projection
- Optional perforation or mini-perforation of the surfaces for suitable surface types

The product is in conformity with the following EU-Standards and other Normative Documents

**EG-Machine Directives 89/392/EWG**  
**EMV-Directive 89/336/EWG**  
**Low-voltage Directive 73/23/EWG**

Applied norms and technical specifications:

**DIN EN 292 Part 1+2**  
**DIN EN 294**  
**DIN EN 349**  
**DIN 19045**  
**DIN EN 55014 Part 1+2**  
**DIN EN 61000-3-2**  
**DIN EN 60335 Part 1**  
**DIN ETS 300220**  
**DIN ETS 300683**  
**DIN ETS 60730**

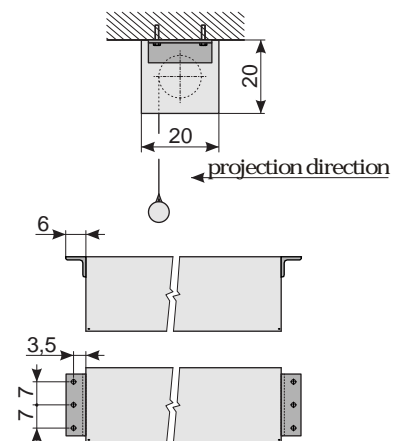
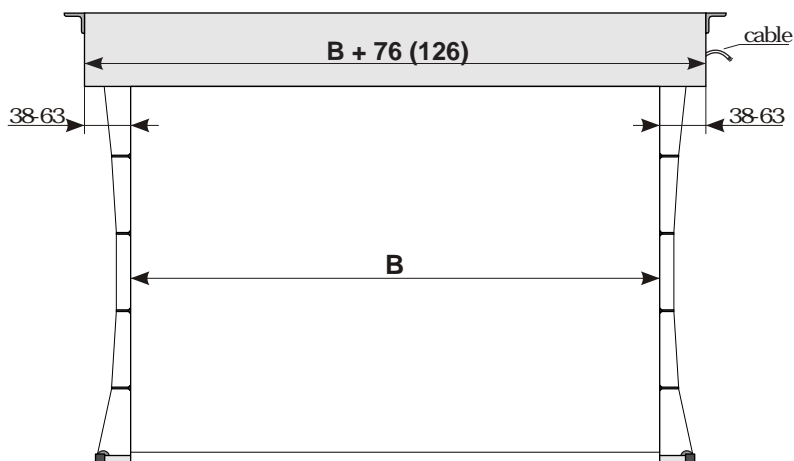

Dimensions in cm

<b>B</b>	400	500	600
----------	-----	-----	-----