

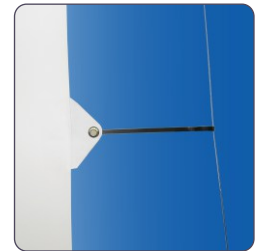

Maxxscreen 27 TabTension



robust case



TabTension system

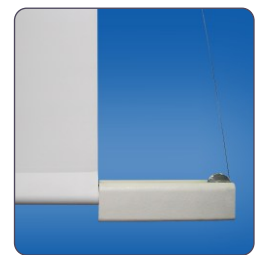

slat bar retracts into the case

Highlights

- Large venue electric screen for trade shows, conference halls, theaters and cinemas
- Up to size of 700 cm width and 600 cm height
- The screen surface is given a high-quality coating after the welding, whereby the horizontal seams are not longer visible
- Perfectly flat viewing area with the use of lateral tensioning system
- High-quality, stable square 27x27 cm steel housing 1 mm steel sheet, white colour RAL9010
- Ceiling installation as standard
- Maintenance - free robust motor incl. thermo protection against overheating
- Easy and safe handling due to an electrical drive, rotary switch included
- Automatic electrical end switch at the top and bottom
- Safety brake preventing the self-unwinding of the canvas

Optional

- Customized sizes, special colour of casing, different types of screens surfaces on request
- RF remote control
- Installation frame for integration into suspended ceilings
- Mounts for wall mounting

Screen surface

- PVC based material with special coating
- Type D - matt white, Gain 1,0 / 1,4 / 1,6, back side white.
- Type S - highly reflective, Gain 1,8
- Type 3D - aluminium silver coating for passive 3D technologies using polarized light, Gain 1,7 / 2,0 / 2,2 / 2,4
- Type R - Rear projection
- Neve - front and rear projection
- Optional perforation or mini-perforation of the surfaces for suitable surface types

The product is in conformity with the following EU-Standards and other Normative Documents

EG-Machine Directives 89/392/EWG
EMV-Directive 89/336/EWG
Low-voltage Directive 73/23/EWG

Applied norms and technical specifications:

DIN EN 292 Part 1+2
DIN EN 294
DIN EN 349
DIN 19045
DIN EN 55014 Part 1+2
DIN EN 61000-3-2
DIN EN 60335 Part 1
DIN ETS 300220
DIN ETS 300683
DIN ETS 60730

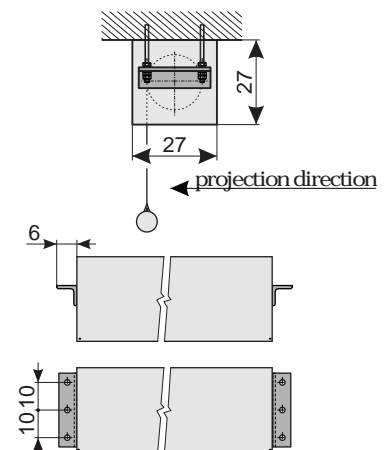
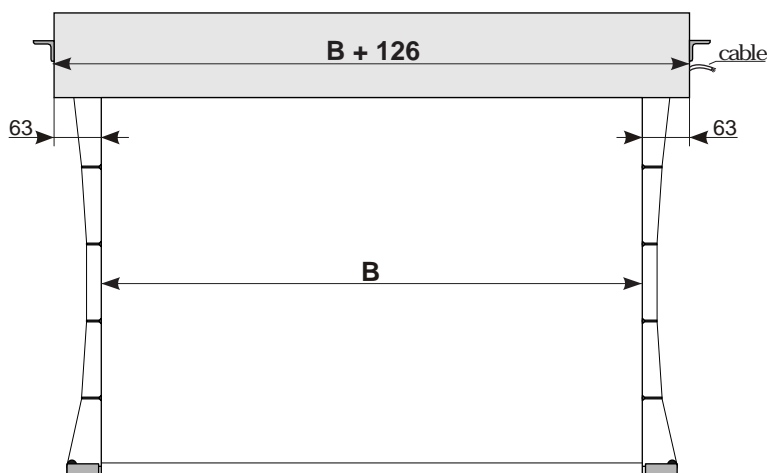

Dimensions in cm

B	600	700
----------	-----	-----